



OMIX-ADA, Inc.

17759.10

460 HORIZON DR. SUITE 400 | SUWANEE, GA 30024 | PHONE: 770-614-6101 | FAX: 770-614-6069 | info@omix-ada.com

# 07+ JK Hood Vent

## Components:

1. Hood Vent	(1)	4. Washer	(30)
2. Button Head Bolt	(16)	5. Button Head Screw	(12)
3. Nylon Lock Nut	(16)		

## Required Tools:

1. Drill
2. 5/32 Drill Bit
3. 13/64 Drill Bit
4. 1" Sheet Metal Hole Saw
4. Scissors
5. Hobby Knife or Razor Blade
6. Center Punch
7. 3 mm Hex Key
8. 8 mm wrench
9. Metal file, or sandpaper
10. Touch-up paint
11. Painter's Tape
12. Electric cutting wheel

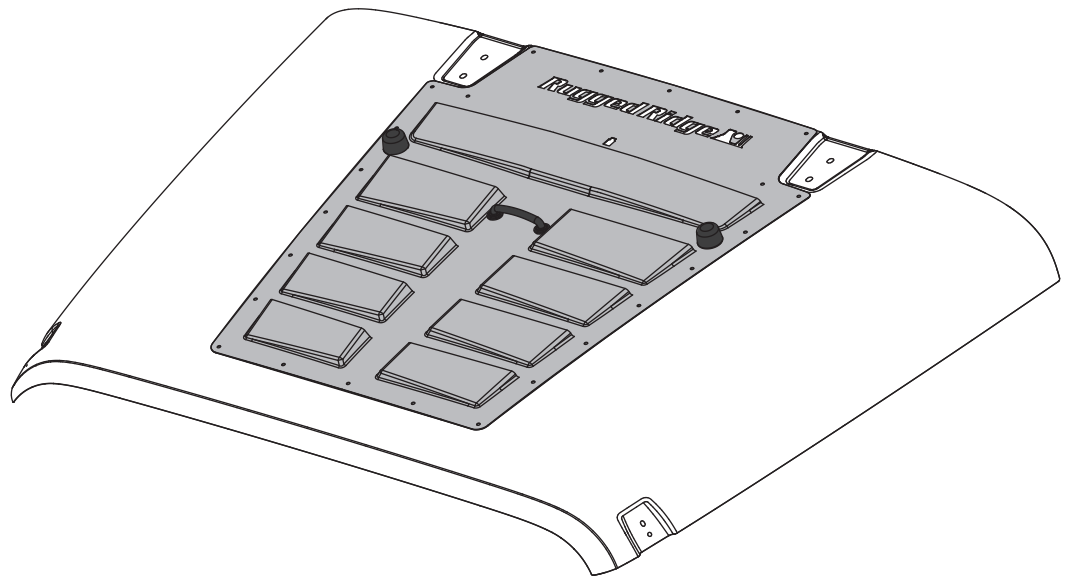

## **! WARNING**

To prevent bodily injury, wear eye protection and use extreme caution during entire installation of this product.

1. Remove hood from vehicle and place on safe working surface such as a table, sawhorse, or a large piece of cardboard.
2. Remove windshield washer nozzle, windshield bumpers, and footman loop.
3. Clean hood with a soft, lint-free cloth and isopropyl alcohol.

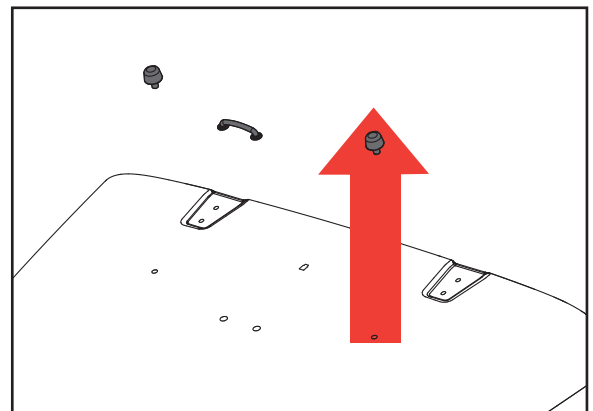

**Read all instructions thoroughly before installation.**

**OMIX-ADA® TECHNICAL SUPPORT**

PHONE: M-F 8am - 5pm EST 1-800-449-6649 | EMAIL: techsupport@omix-ada.com

FOR WARRANTY INFORMATION VISIT: [www.Omix-Ada.com](http://www.Omix-Ada.com)

## 07+ JK Hood Vent

4. Use scissors to cut around outside edge of template.
5. Use a sharp hobby knife or razor blade to cut out windshield bumper holes.
6. Place template on hood and align template by temporarily placing windshield bumpers through windshield bumper holes. Do not push windshield bumpers in enough to snap.

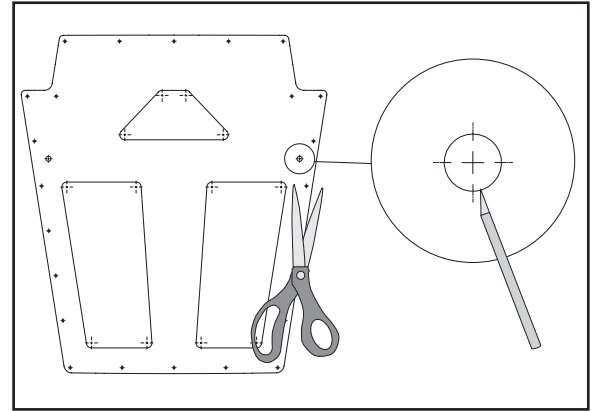

7. Further secure template by taping edges down with painter's tape in three or four locations.
8. Use an automatic center punch, or a punch and hammer, in center of four marked locations in each cutting area. If using a punch and hammer, be careful not to dent your hood.

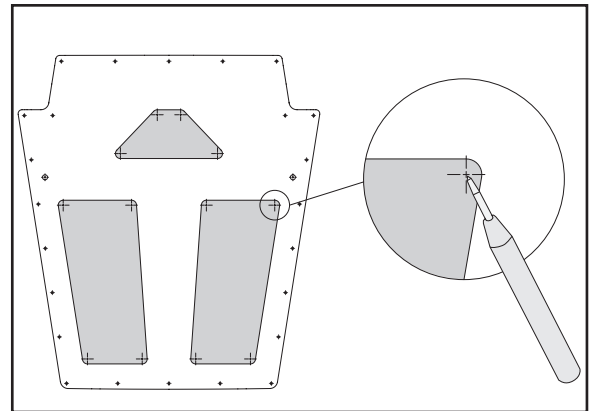

9. Remove template.
10. Use a drill and 1" sheet metal hole saw to drill holes in each location marked with center punch.

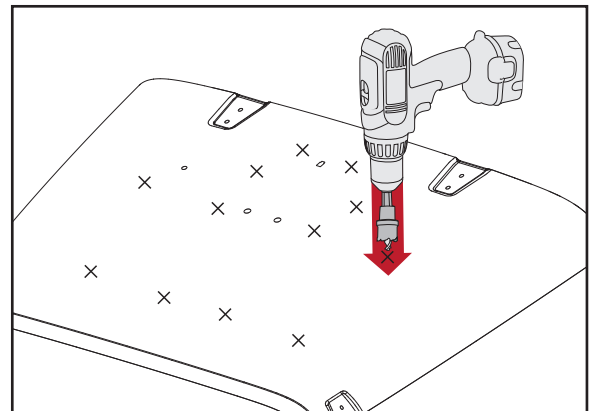

### WARNING

Some hole locations are above support structure "X-brace." It is OK for hole saw pilot bit to drill through X-brace, do not drill through X-brace completely.



OMIX-ADA, Inc.



17759.10

460 HORIZON DR. SUITE 400 | SUWANEE, GA 30024 | PHONE: 770-614-6101 | FAX: 770-614-6069 | info@omix-ada.com

## 07+ JK Hood Vent

11. Use painter's tape to connect each 1" hole with a straight line of tape around outside edges of each hole as shown in template.

12. Carefully use an electric cut off wheel, or rotary tool and metal cutting wheels, to cut top layer of hood sheet metal along inside edge of painter's tape.



### WARNING

Be careful not to cut the underlying X-brace.

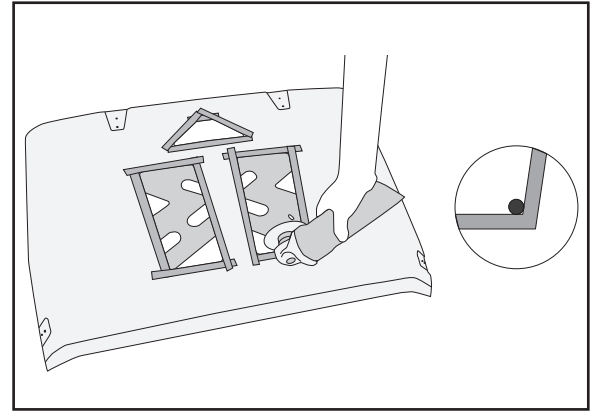

13. Use metal file or sand paper to smooth out rough cut edges in hood sheet metal. Coat exposed metal with touch-up paint to prevent rust.

14. Position Hood Vent on hood, and temporarily reinstall windshield bumpers to ensure proper positioning.

15. Using Hood Vent as a guide, drill holes in top and bottom 4 corners using 13/64 drill bit. Temporarily install 4 bolts, 4 nuts, and 8 washers through these drilled holes, do not over tighten.

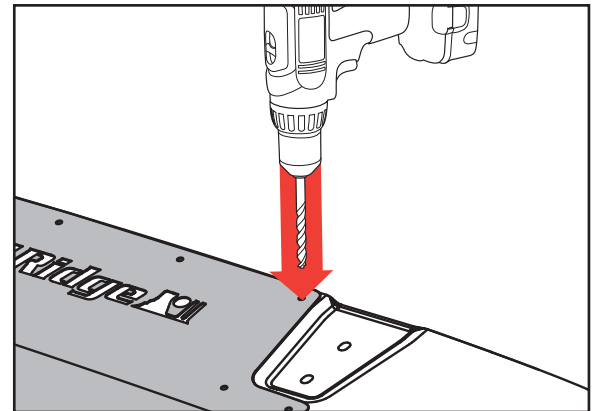

16. With Hood Vent bolted in corners, use Hood Vent itself as a guide to drill remaining holes. Refer to cutting template and guide shown. All holes marked with a "B" for Bolt should be drilled using 13/64 drill bit. All holes marked "S" for Screw should be drilled using 5/32 drill bit. As you go, install a bolt, and nut into each "B" hole, tightening them to finger tight. Try to only drill the "S" holes through hood sheet metal, not through the X-brace.

17. Once all holes are drilled, remove Hood Vent and hardware. Coat all exposed metal with touch-up paint to prevent rust.

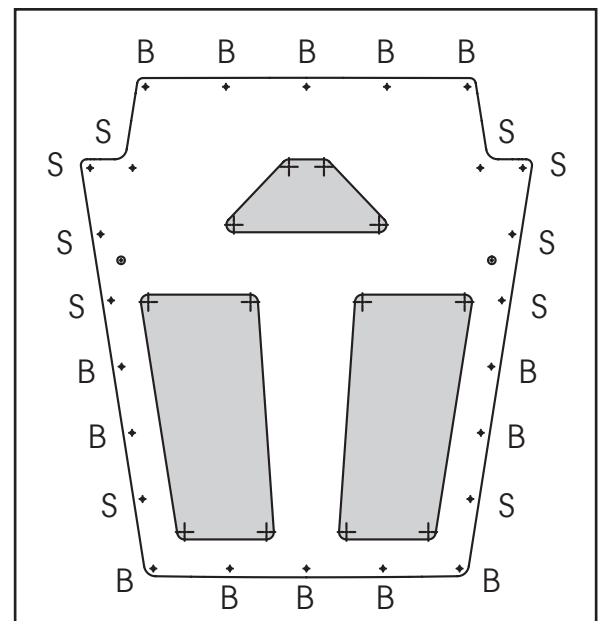



OMIX-ADA, Inc.

17759.10

460 HORIZON DR. SUITE 400 | SUWANEE, GA 30024 | PHONE: 770-614-6101 | FAX: 770-614-6069 | info@omix-ada.com

# 07+ JK Hood Vent

18. Replace hood vent. Install windshield bumpers and footman loop.

19. Install bolts in "B" holes using supplied bolts, two washers, and nyloc hex nut. Install all bolts to finger tight before tightening with wrench and hex key. Do not overtighten.

20. Install screws in "S" holes using supplied screws and one washer. Do not over tighten.

21. Reinstall hood onto Jeep.

